

LABO ★ K EFFECTS

CONNECTION KIT FOR STUDER 963 PREAMPLI+EQUALISER

ISS 1

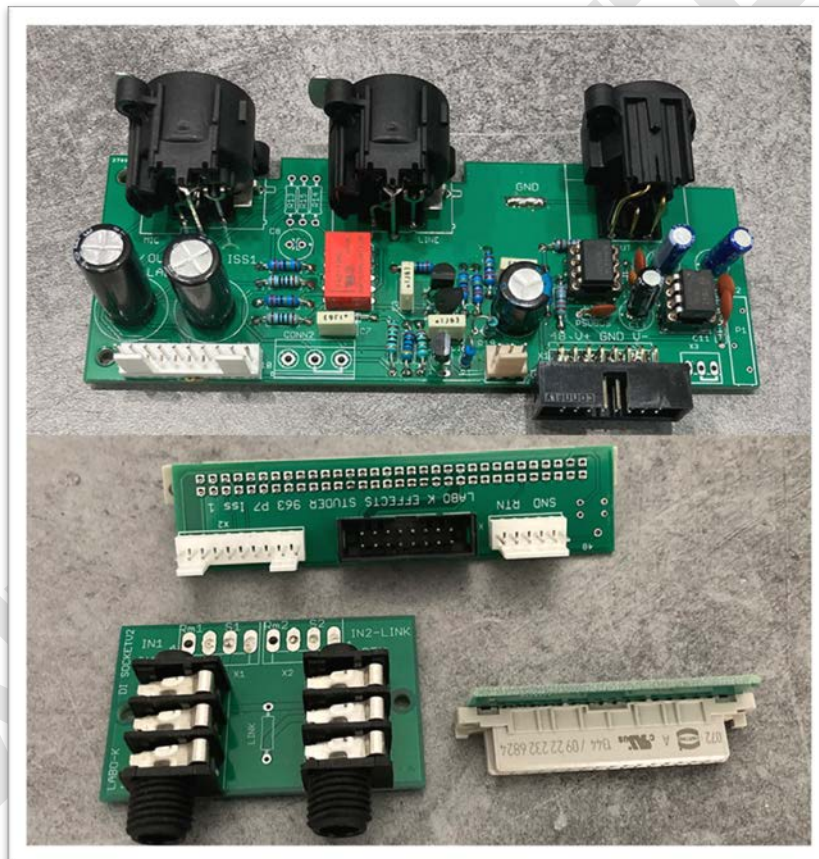

CONTENTS

<i>Introduction</i>	3
<i>Kit contents</i>	4
<i>Agreements</i>	5
<i>Assembly Instructions part 1</i>	6
<i>Assembly Instructions part 2</i>	7
<i>Assembly Instructions part 3</i>	8
<i>Making the connection cables</i>	9
<i>Wiring the elements</i>	10
<i>components list part 1</i>	11
<i>components list part 2</i>	12
<i>Pinouts</i>	13
<i>Drilling template</i>	14

INTRODUCTION

This kit allows to interconnect Studer 963 preamp and equalizer module to put them in a Rack. The kit allows to connect inputs, outputs and power supply necessary for the use of the set.

Optional accessories

Labo★K Effects Studer 963 PSU Kit	
Regulated PSU +48V, +/-15V, -6V (Kit or PCB + Metalwork only) <u>Transformer 2x24V not supplied</u>	



For proper operation of the unit, it is advisable to use modules in good conditions and with coupling capacitors that will have been replaced if necessary.

The poor condition of the capacitors can greatly affect the sound quality or even cut the signal. Similarly, one will ensure that the various switches have been cleaned using a contact cleaner spray.

KIT CONTENTS

- **One board P7 for connecting:**
- **Studer P7 connector (In/out and PSU)**
 - 1 Micro input
 - 1 Ligne input
 - 1 Tape input (optionnal)
 - 1 insertion Snd
 - 1 insertion Rtn
 - 1 Output

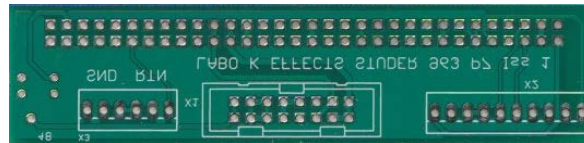

One board P5 for connecting:

- **Studer P5 connector (48V)**
 - 48V PSU



One interface board for connecting:

- The input/output card (P7)
- 1 +4dB balanced output stage (located on the board).
- The power supply of the card
- An output potentiometer (Not supplied)
- An optional High impedance input

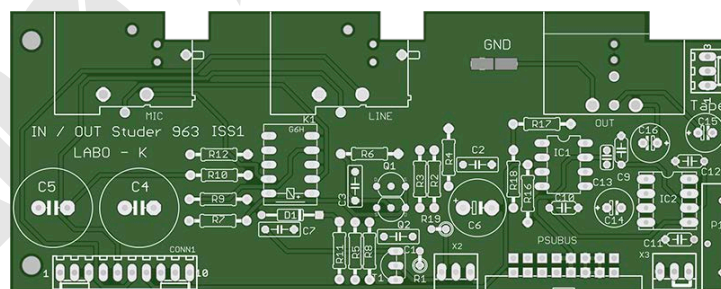

- **One board for connecting :**
Send and Return insertion connectors.
A TAPE input (Tape connector) is provided.

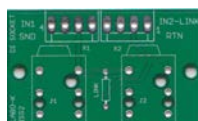

AGREEMENTS

Component layout

Vertical layout of diodes

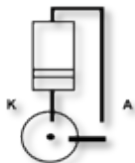

Straps are made using component tails.

The tabs of the Molex KK connectors is located on the edge of the board.



Locating

Pin 1 of the Molex KK connectors is on the left.

Pin 1 of the IDC connectors is marked with a triangle.

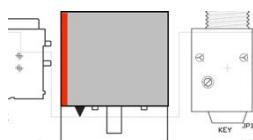

Wiring

Molex connectors

The various connections via male Molex KK connectors are made using soldered wires sleeved onto the pins.

It is of course possible to crimp the cables into female Molex KK connectors (not supplied) to make these connections.

KK female connectors to be used

Molex **KK254**

Crimps **08-50-0032**

IDC connectors

Only IDC connectors are supplied with the kit.

The ribbon cable to be used is 28 AWG pitch 1.27 with 16 strands.

For IDC 10 connectors, 6 strands must be removed from cable 16, keeping the red strand. The ribbons in the VU/Gain reduction section have 20 strands to be separated into 2 x 10 once the 20-pin connector has been crimped. This will form a Y with 2 10-pin connectors at the end of the 2 legs.

Shielded cables

The instrument input and potentiometer are wired using shielded pairs such as Mogami 3931-2 pairs, for example. 1 meter will be sufficient for 2 channels.

ASSEMBLY INSTRUCTIONS PART 1

Implementation of Basic version components

Areas of the board not used for this kit are hidden.

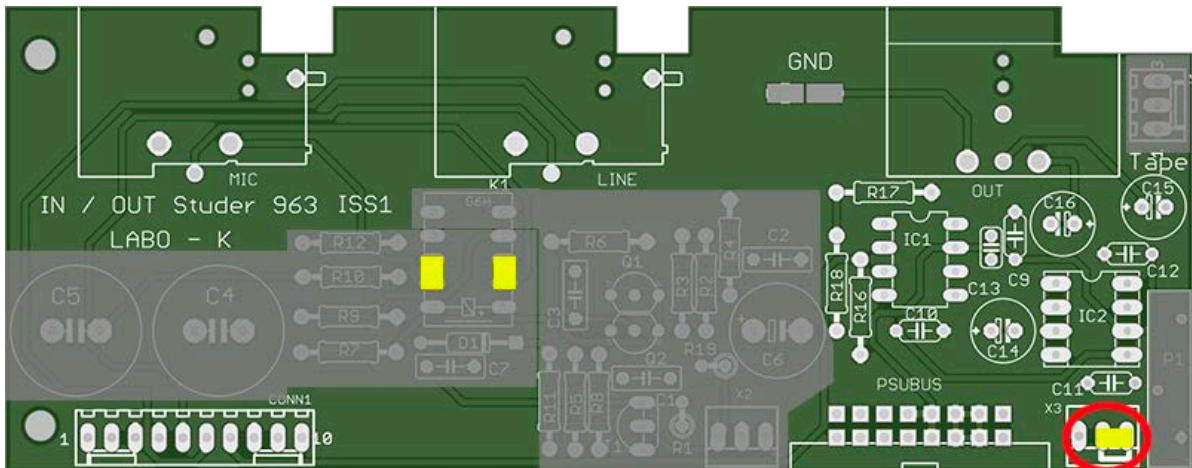

Place straps (component tails) at the points marked with yellow lines.

It is possible to wire an output potentiometer (not supplied).

In this case, do not fit the jumper surrounded by a red circle.

Wiring the optional 10K linear potentiometer with a shielded wire
(Ground shown in black)

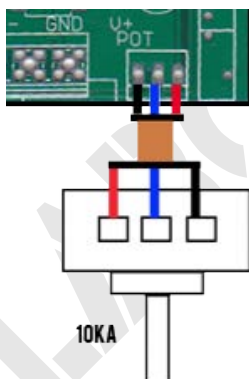

A 3-pin Molex connector is planned.

To connect pin 1 of the output XLR to earth, connect the 2 GND pads with solder..

DI version component layout

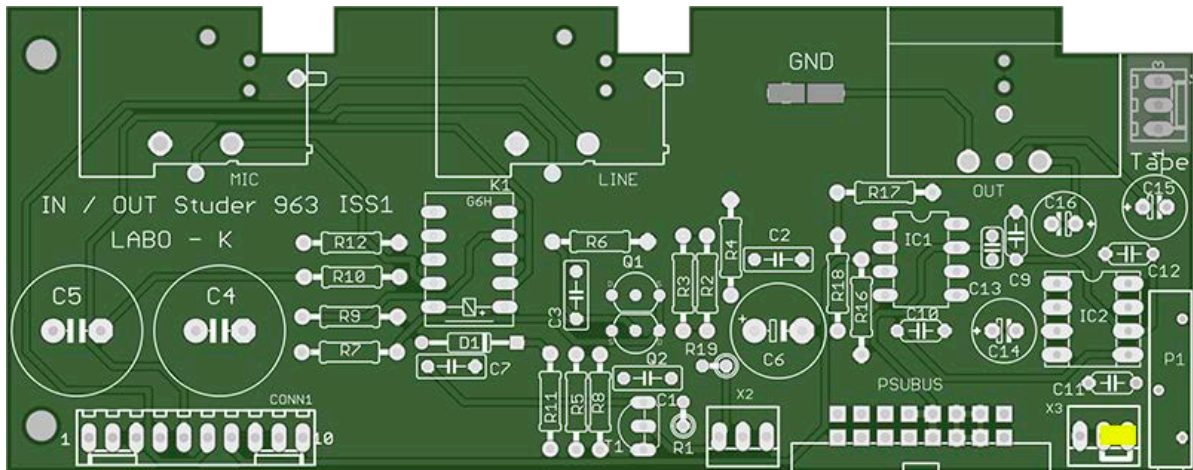

Fit a jumper (yellow line) if the volume potentiometer option is not used.

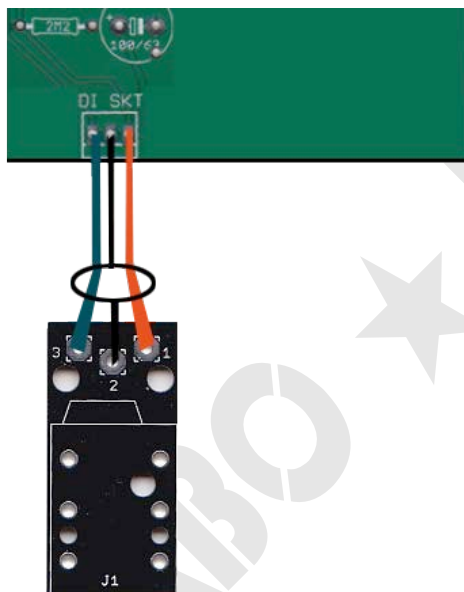

A 3-pin Molex connector is planned.

ASSEMBLY INSTRUCTIONS PART 3

Insert wiring

The SND and RTN jacks are wired in Half Normalised mode.
If no jack leads are inserted, the signal from the SND (Send) jack returns directly to the RTN (Return) jack.
Inserting a jack cord into the RTN input breaks the signal path coming from the SND jack

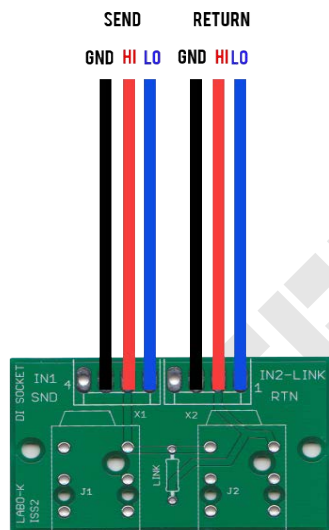

Placing a jumper on the P7 card selects the position of the Pre or Post fader output.

MAKING THE CONNECTION CABLES

The PSU ribbon connects the power supply to the Input interface card and the P7 card. Once the components have been positioned in the rack, you need to measure the length required to connect the cards and the power supply, then cut a ribbon to the required length. Use a marker to mark the position of the connectors on the ribbon. Finally, crimp the female connectors to the previously marked positions. It is very important to mark pin 1 (Triangle) and to place the red wire of the ribbon on this side.

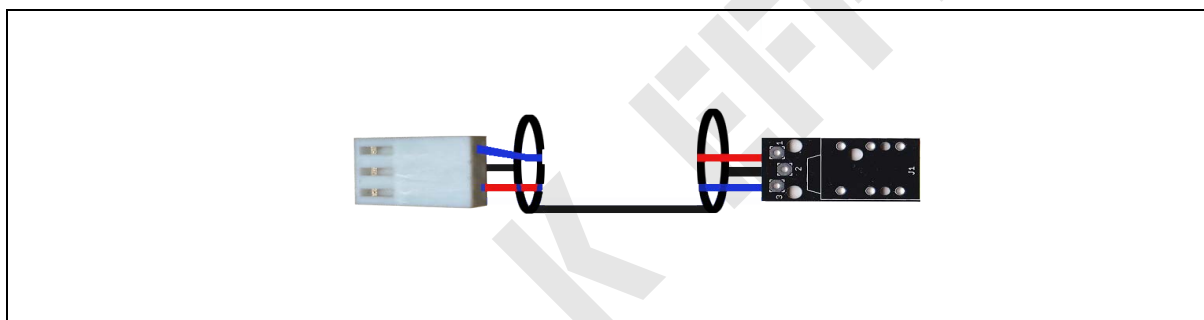
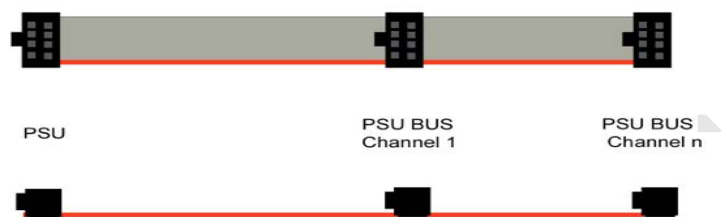

The DI cable links the jack connector to the instrument input on the Input Interface card. A shielded pair must be used. One of the cables carries the signal from the instrument, while the second controls the DI activation relay depending on whether or not a jack is inserted in the connector on the front panel. The XLR Micro is thus disconnected and the instrument, after impedance matching, uses the Micro signal path.

WIRING THE ELEMENTS

Connections between the P7 card and the I/O card are made using shielded cables soldered to the pins of the Molex connectors. It is of course possible to crimp these cables onto female Molex connectors.



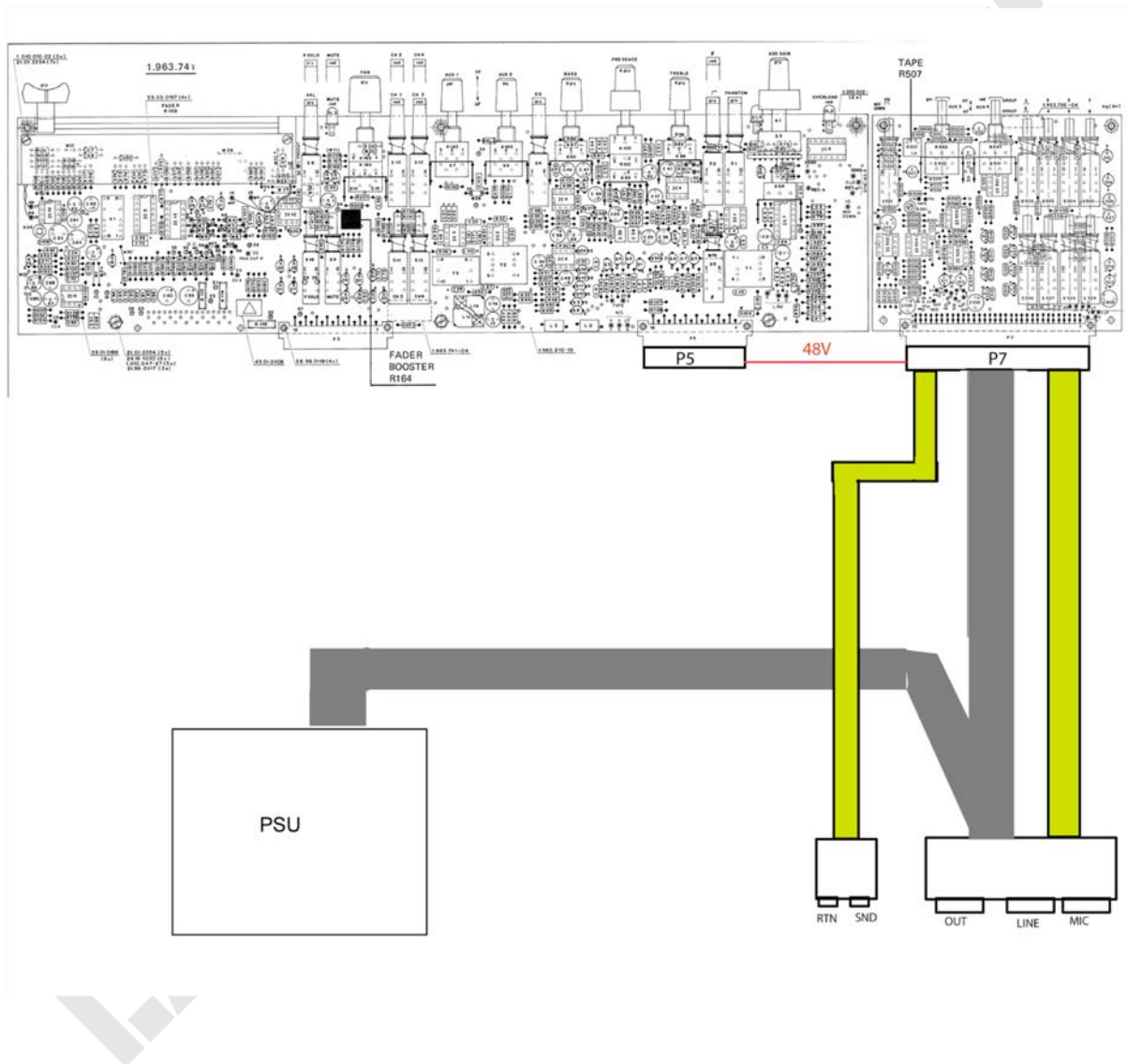



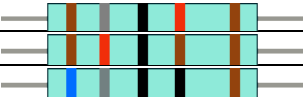





A single cable must be used to connect the points marked 48 on the P7 and P5 boards.



COMPONENTS LIST PART 1

P7 board			
NAME	VALUE	VISUAL	REFERENCE
X2	Connector KK10		
X3	Connector KK6		
Conn 1	DIN 41612		
X1	Connector IDC 16		
P5 board			
	Connector IDC 10		
Interface board			
R16	18K		
R17	1K2		
R18	680R		
C9	100n ceramic		
C10	100n ceramic		
C11	100n ceramic		
C12	100n ceramic		
C13	22p		
C14	100uF 16V		
C15	22uF 25V		
C16	22uF 25V		
IC1	NE5534 +Socket		
IC2	THAT 1646 + Socket		
Conn Mic	XLR 3 F		
Conn Line	XLR 3 F		
Conn Out	XLR 3 M		
Bus PSU	Connector IDC 16M		
Conn 1	Connector KK10		
Insertion board			
J1	Jack TRS		
J2	Jack TRS		
Connections			
P7	Connector IDC16 F		
PSU BUS	Connector IDC16 F		

COMPONENTS LIST PART 2

High impedance instrument input option			
NAME	VALUE	VISUAL	REFERENCE
R1	2M2		
R2	2M2		
R3	2M2		
R4	2M2		
R5	470R		
R6	2M2		
R7	100R		
R8	22R		
R9	2M2		
R10	100R		
R11	3K		
R12	2M2		
R19	10K		
C1	100n Film		
C2	100n Film		
C3	100n Film		
C4	100u BP		
C5	100u BP		
C6	100u63V		
C7	100n Film		
D1	1N4148		
T1	2N3904		
Q1	K170 BL		
Q2	K170 BL		
K1	EA2-12NU	Relay 12V	
Jack+PCB	Connector KK 3		

PINOUTS

Input Interface & P7

Conn 1	
1	Mic in Lo
2	Mic in Hi
3	Mic Screen
4	Line Screen
5	Line in Hi
6	Line in Lo
7	Out unbal
8	Out screen
9	Tape in Hi
10	Tape in Lo

INST	
1	Input
2	GND
3	Remote

INSERT	
1	SND Lo
2	SND Hi
3	SND screen
4	RTN screen
5	RTN Hi
6	RTN Lo

PSU BUS	
1	+48V
2	+48V
3	GND
4	GND
5	GND
6	GND
7	+15V
8	+15V
9	+15V
10	Nc
11	NC
12	-6V
13	-6V
14	-15V
15	-15V
16	-15V

DRILLING TEMPLATE

External view of the rack

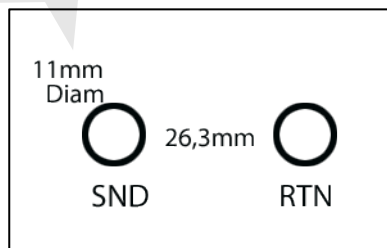
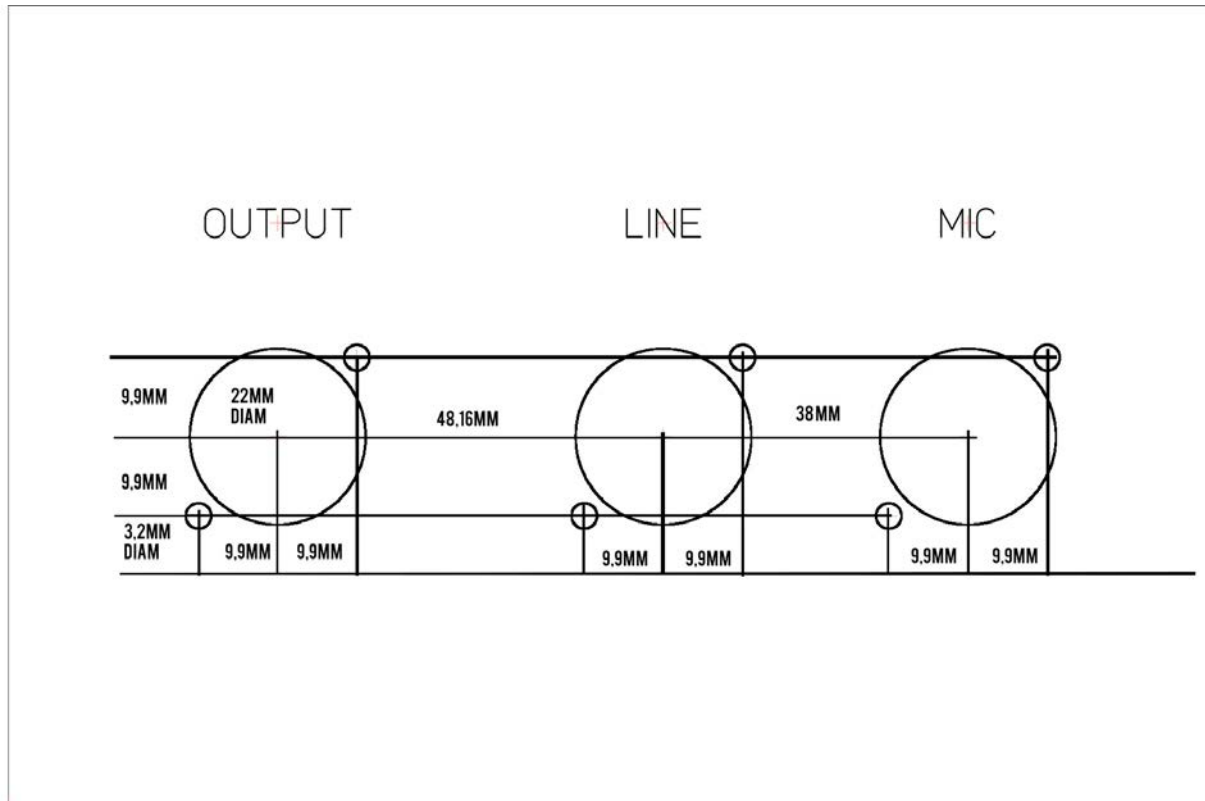

Mentions légales :

Labo★K Effects shall not be responsible and disclaims all liability for any damage (whether direct or consequential) that may result from a wrong use of the kit by the user.